

THIS DRAWING IS THE PROPERTY OF PRIMARY FLUID SYSTEMS INC. FROM WHICH A WRITTEN CONSENT FOR APPROVAL SHALL BE REQUIRED PRIOR TO COPYING.

	NO.	NAME	DESCRIPTION
	1	MAX ALLOWABLE OPERATING TEMPERATURE	260 °F (125 °C)
	2	MAX ALLOWABLE OPERATING PRESSURE	150 PSIG
CONNECTIONS	3	INLET PORT CONNECTION	3/4"
	4	OUTLET PORT CONNECTION	1"
MATERIALS	5	TYPE	NPT
	6	BODY, QUILL AND CHECK SEAT	PVDF
	7	GLAND	PVDF
	8	GLAND SEAL	VITON (EPDM OPTIONAL)
	9	VALVE ASSEMBLY	PVDF

CS CORPORATION STOPS

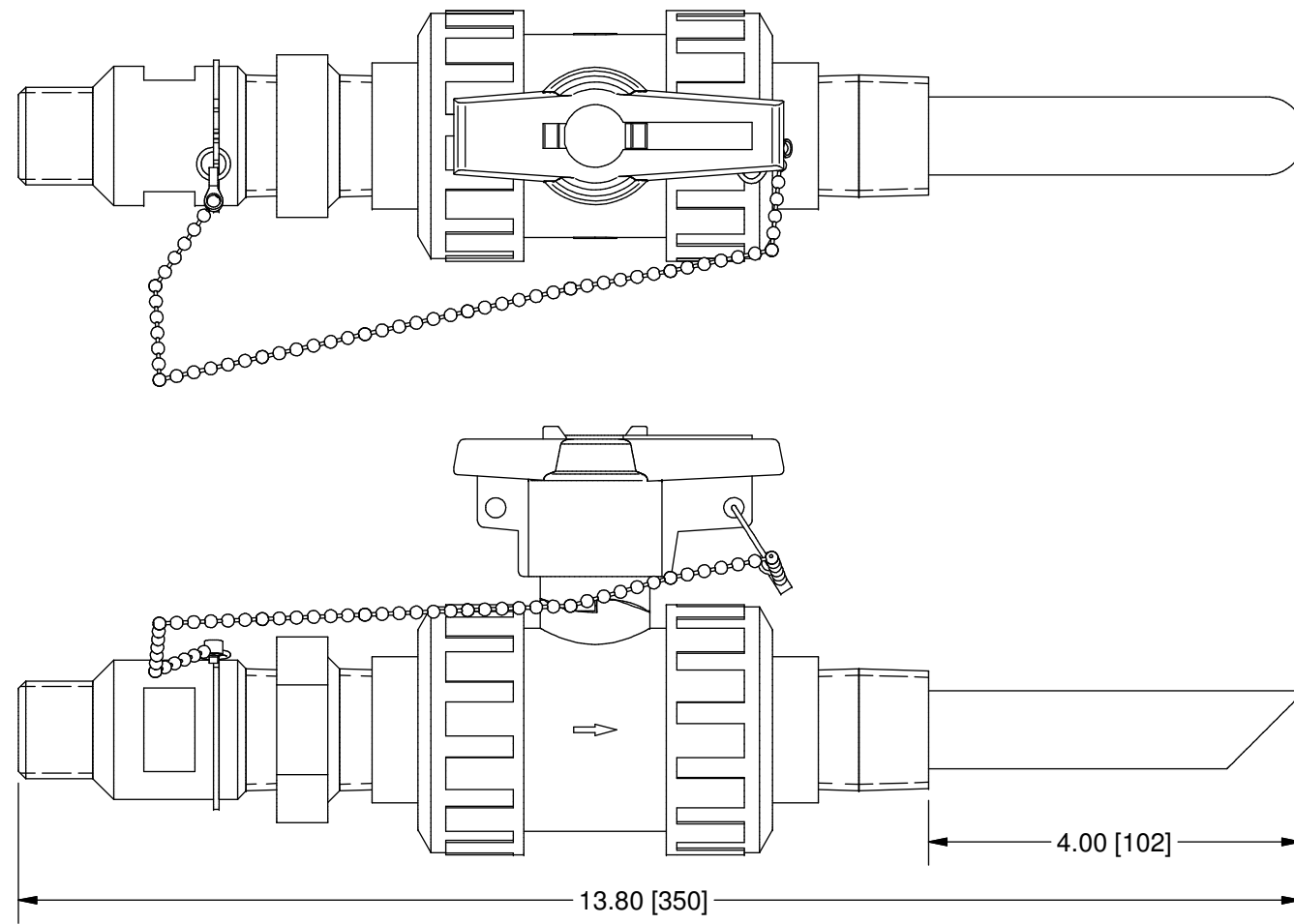

SCALE 1 : 2

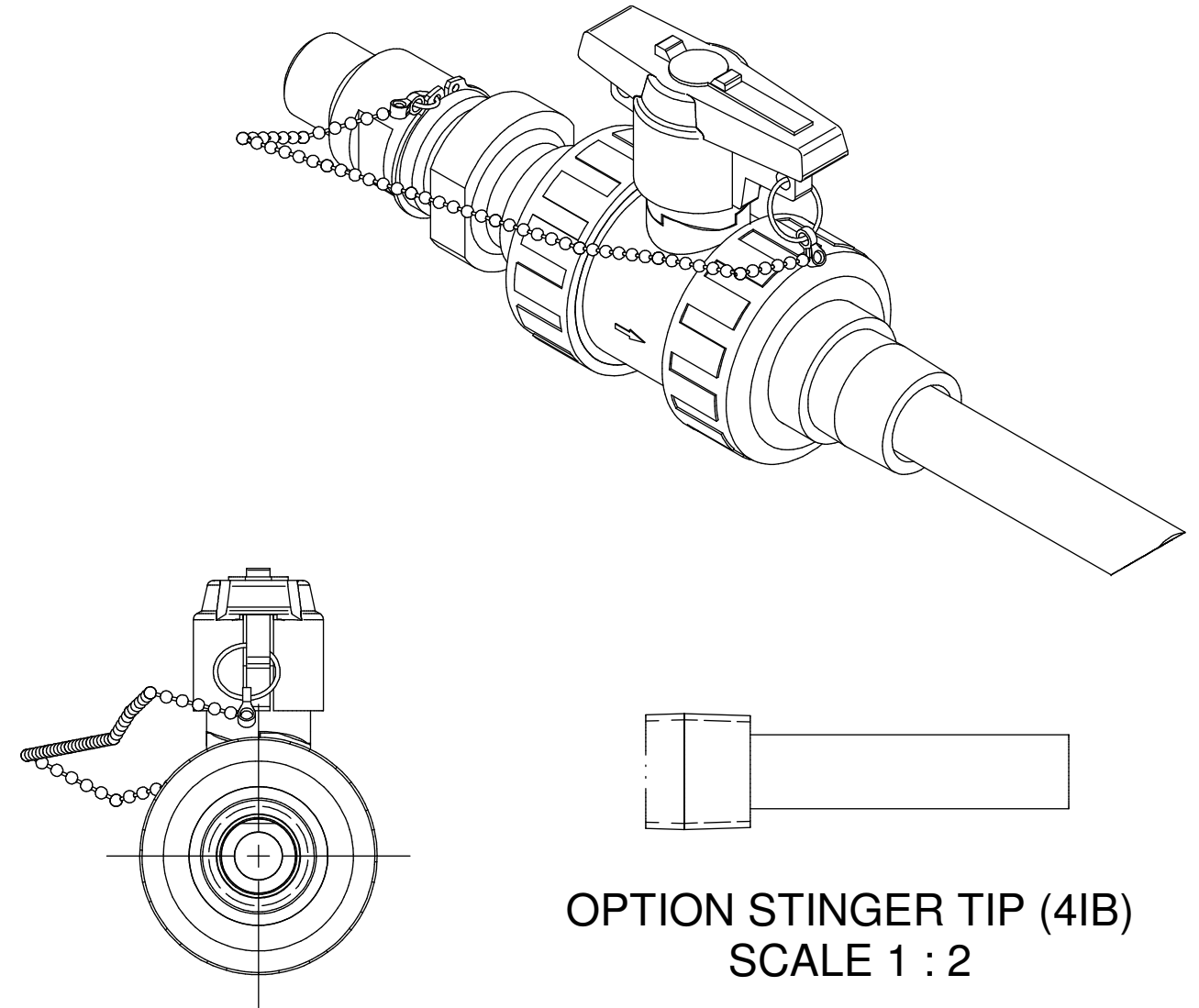

REV	DESCRIPTION	DATE	NAME
0	NEW DRAWING	--	--

PRIMARY FLUID SYSTEMS INC. 1050 COOKE BLVD, BURLINGTON, ONTARIO L7T 4A8		PROJECT: CS	SHT: 1 OF 1	DRAWN BY: BL
TITLE: CORP STOP WITH 3/4" INLET AND 1" OUTLET NPT CONNECTIONS		DATE DRAWN: 8/27/2024	SCALE: 1 : 2	UNITS: INCH [mm]
DWG NO: CS-75A10A-4IA-DDDV_R0		MATERIAL: SEE CHART	REV# 0	
DWG NAME: CORP STOP DWG TYPE: PLANAR VIEW		DWG NO: CS-75A10A-4IA-DDDV_R0	DIMENSIONAL TOLERANCE 0.X = ± 0.25" 0.XX = ± 0.25" 0.XXX = ± 0.25"	
APPROVED BY: _____ CHECKED BY: _____		THIRD ANGLE PROJECTION 		