

THIS DRAWING IS THE PROPERTY OF PRIMARY FLUID SYSTEMS INC. FROM WHICH A WRITTEN CONSENT FOR APPROVAL SHALL BE REQUIRED PRIOR TO COPYING.

	NO.	NAME	DESCRIPTION
CORPORATION STOP	1	MAX ALLOWABLE OPERATING TEMPERATURE	210°F (98°C)
	2	MAX ALLOWABLE OPERATING PRESSURE	150 PSIG @70°F (21°C)
CONNECTIONS	3	INLET PORT CONNECTION	1"
	4	OUTLET PORT CONNECTION	1"
	5	TYPE	NPT
MATERIALS	6	BODY AND QUILL	CPVC (CORZAN)
	7	GLAND	CPVC (CORZAN)
	8	GLAND SEAL	VITON (OPTIONAL EPDM)
	9	VALVE ASSEMBLY	CPVC (CORZAN)

CS CORPORATION STOPS

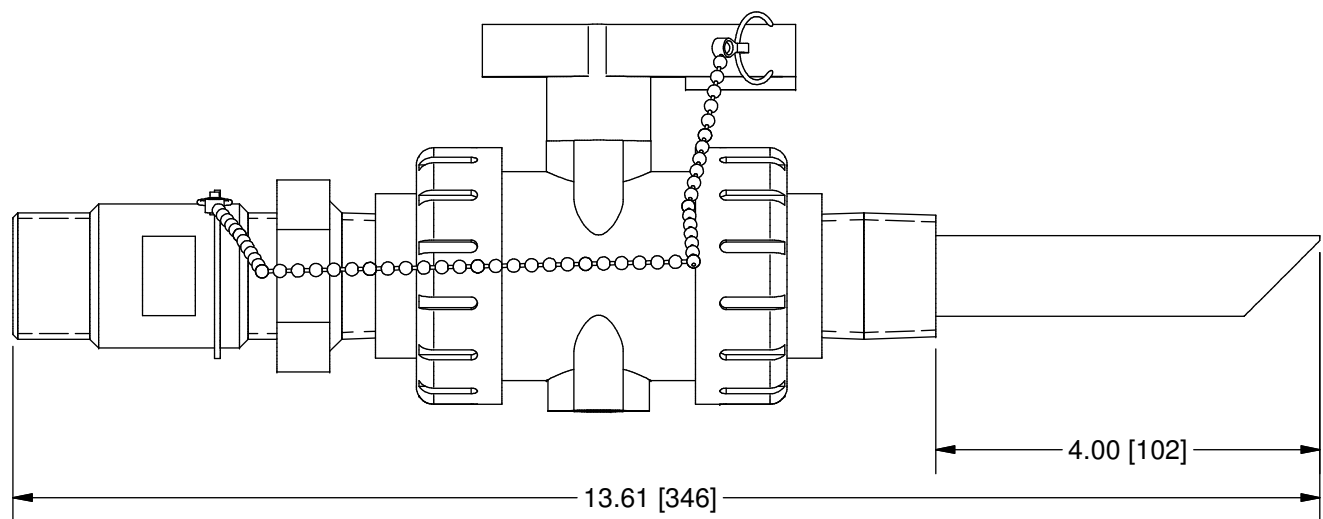
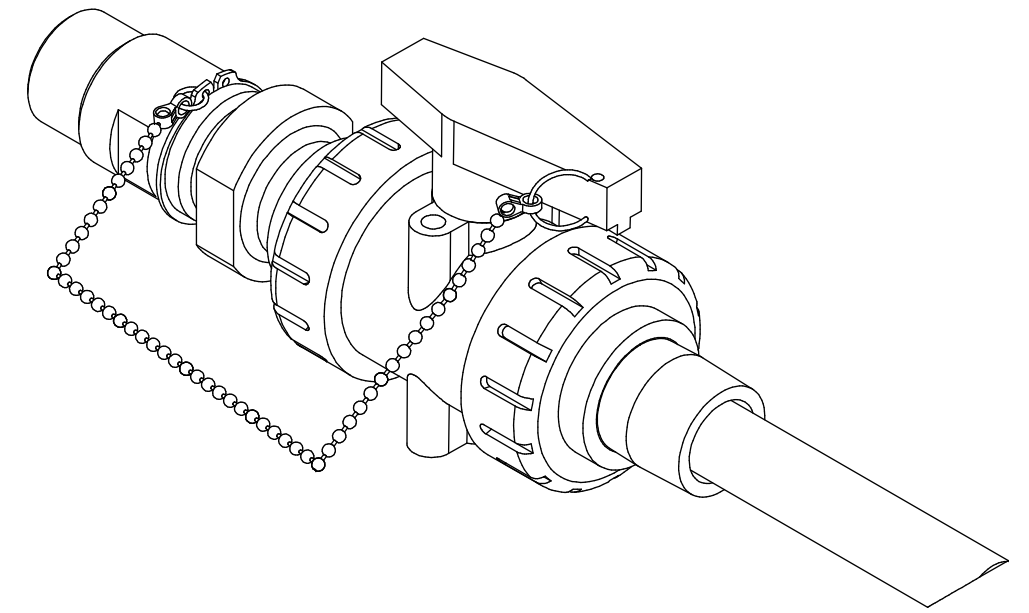
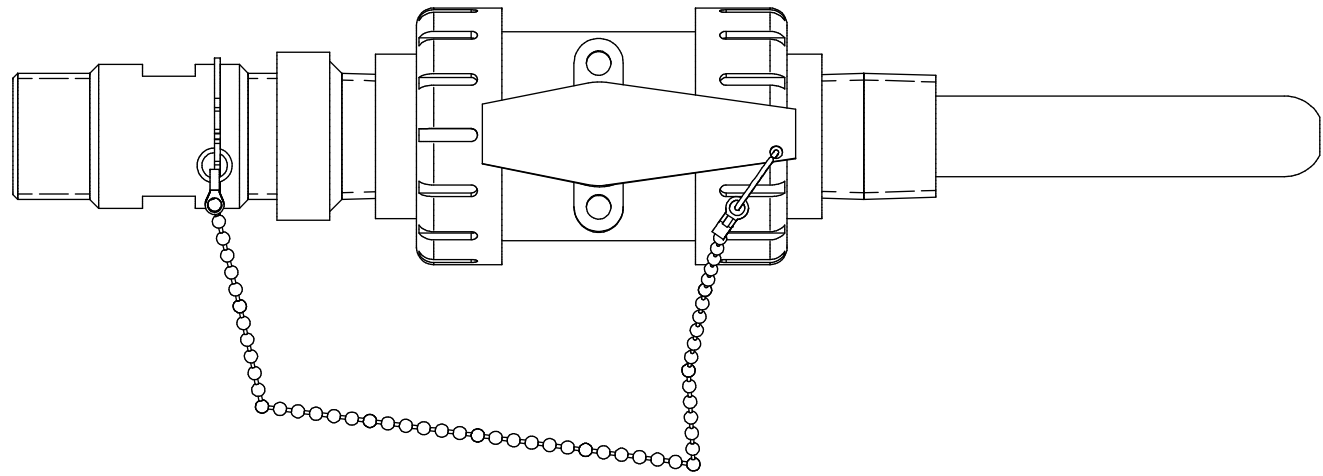

SCALE 1:2

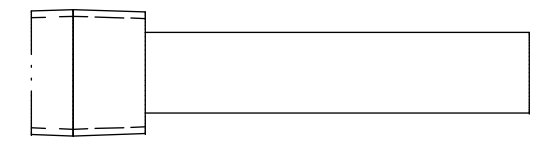
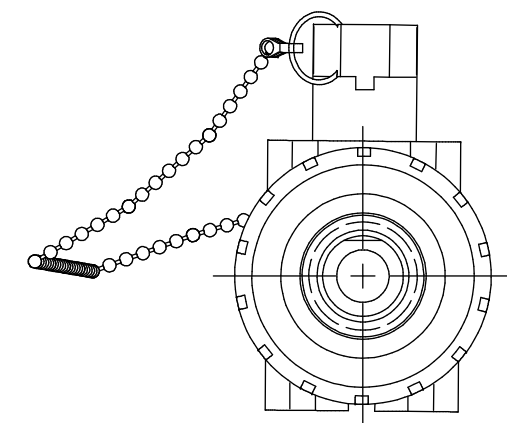

OPTION STINGER TIP (41B)
SCALE 1:2

PRIMARY FLUID SYSTEMS INC. 1050 COOKE BLVD, BURLINGTON, ONTARIO L7T 4A8		PROJECT: CS	SHT: 1 OF 1	DRAWN BY: BL
TITLE: CORP STOP WITH 1" INLET AND 1" OUTLET NPT CONNECTIONS		DATE DRAWN: 8/28/2024	SCALE: 1 : 2	UNITS: INCH [mm]
DWG NO: CS-10A10A-41A-BBBV_R0		MATERIAL: SEE CHART	DWG NAME: APV	REV# 0
DWG TYPE: PLANAR VIEW		APPROVED BY:	CHECKED BY:	DIMENSIONAL TOLERANCE 0.X = ± 0.25" 0.XX = ± 0.25" 0.XXX = ± 0.25"

REV	DESCRIPTION	DATE	NAME
0	NEW DRAWING	--	--

REVISION HISTORY