

# ECO Valve

Uses:

- Back Pressure valve
- Anti-Siphon valve
- Pressure Sustaining valve
- Pressure Relief valve

## Instruction Manual

1/2", 3/4", and 1" ("B" Series)

**ECOT-55, ECOT-75, ECOT-100**  
**High Temperature**

**Please note:**

This instruction manual provides detailed information and instructions that must be read, understood and followed to ensure that the equipment is installed, operated and serviced in an appropriate manner. Failure to do so before using may result in hazardous consequences and/or improper operation.

Manufactured by:



**PRIMARY FLUID  
SYSTEMS INC.**

1050 Cooke Blvd., Burlington, Ontario, L7T 4A8

Tel: (905) 333-8743

Fax: (905) 333-8746

Call Toll Free: 1-866-324-6422

E-Mail: [sales@ecovalve.ca](mailto:sales@ecovalve.ca)

<http://www.ecovalve.ca>

## Introduction

The following instructions are to provide information on the Installation, operation and maintenance of ECO Valve, diaphragm style valves, manufactured by Primary Fluid Systems Inc. The valves are designed to help improve the performance and safe operation of most positive displacement pumps.

Various materials of construction are available dependent on the requirements of the application and the type of fluids being transferred.

The valve(s) are factory set at 50 PSIG with a field adjustment range of 15-150 PSIG. Other factory set pressure ranges (within the range of the valve) is available upon request.

### Features of ECO Valve:

- 316 S/S, Hastelloy C or Alloy 20 wetted construction
- Aluminum top standard, 316 S/S top optional
- Viton diaphragm standard
- EPDM diaphragm optional
- Maximum temperature of 300°F or 149°C
- Only one elastomer is present in the wetted end
- Turn down handle limits pressure to 150 PSIG
- Locking adjustable pressure screw
- Color-coded caps indicate size at a glance
- Built-in gauge port on both sides of valve body (pre-drilled & threaded optional)
- Specially designed spring provides consistent pressure adjustments through the range (15-150 PSIG)
- Eco valve is available in several configurations to meet your needs, such as threaded, socket, flanged, union in DIN, BSPT and American Standard
- Built-in downstream manual air release, for ease of pump priming
- Built-in anti-siphon

**\*Pressures under 15 PSIG require rubber elastomeric diaphragm.**

### Back Pressure Valve/Anti-siphon:

Diaphragm Back Pressure Valves serve two primary functions. The first is to provide a constant discharge pressure on the pump, which improves the performance, efficiency and consistency of the delivered volume. Secondly, the valve performs as an anti-siphon mechanism against positive or negative pressures in the downstream line. The valve is designed to allow for the venting of air into the downstream pipeline. This provides for easier priming of metering pumps that function under a suction lift. This is accomplished by a simple adjustment of the handle.

The valve comes complete with a gauge port located on both sides of the valve body; the ports are normally not drilled or tapped for a gauge connection. **(See *gauge installation instructions on page 5*)**

#### Caution:

**The gauge port is solely for the installation of the gauge and must not be used for the bleeding or venting of the system. Improper operation of the valve and/or hazardous consequences could result. (See *gauge installation instructions*)**

## **Back Pressure /Pressure Sustaining Valve: Reason for Selection and Use**

Metering pumps having an atmospheric discharge system pressure or less than 20 psi will benefit from the installation of a back pressure control valve. Metering pumps in general require downstream back pressure to ensure smoother function of the discharge check assemblies, which enhances the accuracy of the discharge flow.

### **Pressure Relief Valves:**

Diaphragm Pressure Relief Valves are designed to relieve excess line pressure that exceeds the set pressure of the valve. This protects the system piping from overpressure that could result in hazardous leakage and/or damage to the pump and other system components.

The Pressure Relief Valves are normally recommended to be set between 5 and 10 PSIG above the system operating pressure.

When ECO valves are used as a pressure relief valve it is a two port valve, thus designed for off line installations. This requires the valve to be installed on a tee branch of the discharge line of the pump for piping back to supply tank or feed side of pump.

The valve comes complete with a gauge port located on both sides of the valve body; the ports are normally not drilled or tapped for a gauge connection. **(See *gauge installation instructions on page 5*)**

#### **Caution:**

**The gauge port is solely for the installation of the gauge and cannot be used for the bleeding or venting of the system. Improper operation and/or hazardous consequences could result. (See *gauge installation instructions*)**

## **Pressure Relief Valves: Reason for Selection and Use**

Most positive displacement pumps require the use of a pressure relief valve; it should always be installed on the downstream side of the pump to protect the system from over pressure which can cause pipe leakage and/or rupture. There should not be any type of valve located between the pump discharge or the pressure relief valve, for the pressure relief valve to function properly.

### **Installation and Maintenance of Back Pressure Valves:**

Back pressure control valves are installed on the discharge line of the pump. The valve should be located as reasonable close as possible of the pump discharge to ensure check valve seating. When pumping to a process line without an injection valve, the back pressure valve should be installed as close as possible to the injection point to prevent siphoning.

When used in conjunction with a pressure relief valve, always locate the back pressure valve on the downstream side of the relief valve.

The valve is supplied from the factory pre-set at 50 psig. To increase the pressure setting, back off the lock nut located beneath the colour coded bonnet cap. Turn the Allan bolt using a 5/16" or #8 hex key clockwise to increase pressure setting or counter clockwise to reduce pressure setting. Approximately one (1) full turn of the handle is equal to 10 psig.

If maintenance is required on the valve:

1. Ensure that the valve is **properly isolated** from the line, **not under pressure** and **properly flushed** of chemical before proceeding to disassembly.
2. Turn Allan bolt on the top of valve, counterclockwise until all spring pressure is released **before** proceeding to undo retaining nuts, to remove top of valve for diaphragm replacement.
3. All working components ie. diaphragm, spring can be accessed by removing the four retaining bolts located on the bottom of the valve (item # 9 of parts breakdown). Use a 3/16" Allan key or #5 hex key to remove the retaining bolts.
4. When replacing a PTFE coated diaphragm, ensure the PTFE coated side of the diaphragm is facing down when viewed from the top of the valve. The installed diaphragm also functions as the body seal. (Torque nuts to 55 inch pounds when reassembling )

### **Installation and Maintenance of Pressure Relief Valves:**

Pressure relief valves are installed on the discharge line of a pump and should be located as close as possible to the metering pump. The valve is of an two port design and is required to be installed on a branch tee for piping back to the supply tank or feed side of the pump.

Never install shut-off/isolation valves between pump discharge and in-line pressure relief valves. When using in conjunction with a back pressure control valve, always install back pressure valve downstream of pressure relief valve. The relief port on the pressure relief valve should be piped back to the feed tank or suction side of the pump (see typical installation schematics).

**Caution: The plastic valve bodies have standard threads, which are tapered.  
When installing pipe into the body, hand tighten only to avoid cracking.**

### **Gauge Installation Instructions:**

For the convenience of pressure setting and reading, there are two ports provided one on either side of the valve body. These ports are normally not drilled or tapped unless initially ordered that way. To drill and tap the ports it is recommended that you first disassembly the valve so as to not leave any foreign particles in the valve. You will require a 1/8" or 3.264 mm drill bit to drill out the centre point of the gauge port opening into the body of the valve. The port is already the correct diameter for the tapping of a 1/4" or M10 thread. It is recommended that you use a regular tap then a bottoming tap to open the port up, this will allow for the proper number of gauge threads.

# Manual Air Release

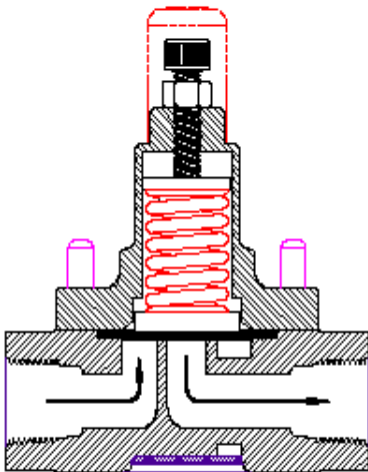

**DIAPHRAGM POSITION AT  
50 PSI BACK PRESSURE**

The valve is shipped with a factory set pressure of 50 psig. The diagram to the left shows a cut away view of the position of the diaphragm on the seat.

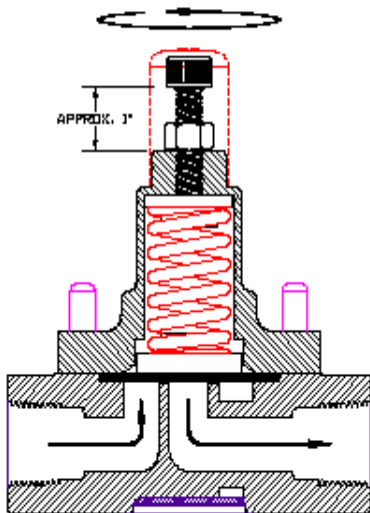

**AIR RELEASE POSITION WITH  
HANDLE BACKED OFF**

To adjust the valve to relieve air or gas downstream:

1. Back off lock nut located beneath the colour coded handle.
2. Turn handle counter clockwise until approximately 1 inch of thread is exposed.
3. At this adjustment, the spring has relieved all tension from the diaphragm allowing air or gas to be vented downstream.

## Typical Installations

The installations below are typical installation examples only. Consult your engineering department for the appropriate installation for your application or call the factory for advice

### Example A: Solenoid Driven Pumps Rated Under 150 psig

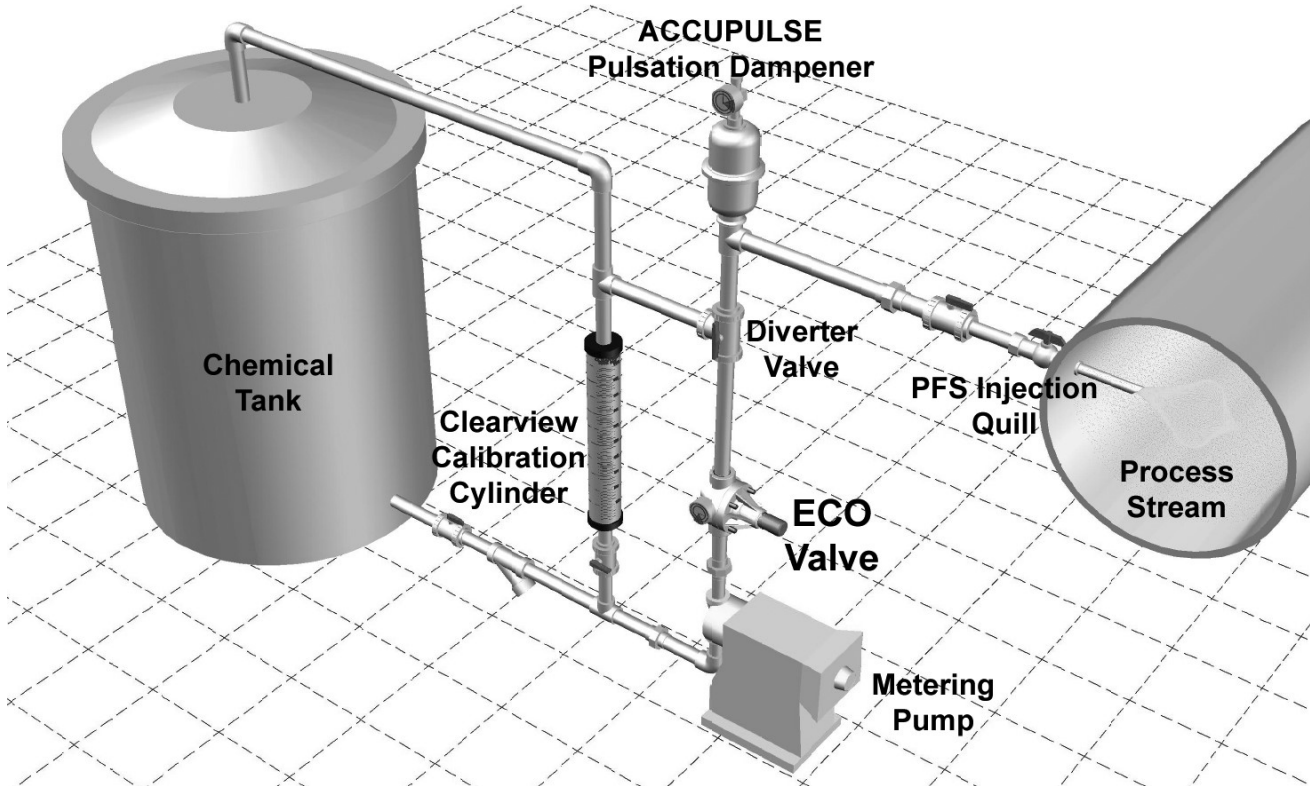

### Example B: System arrangement for solenoid driven (above 150 psig) or motor driven pumps.

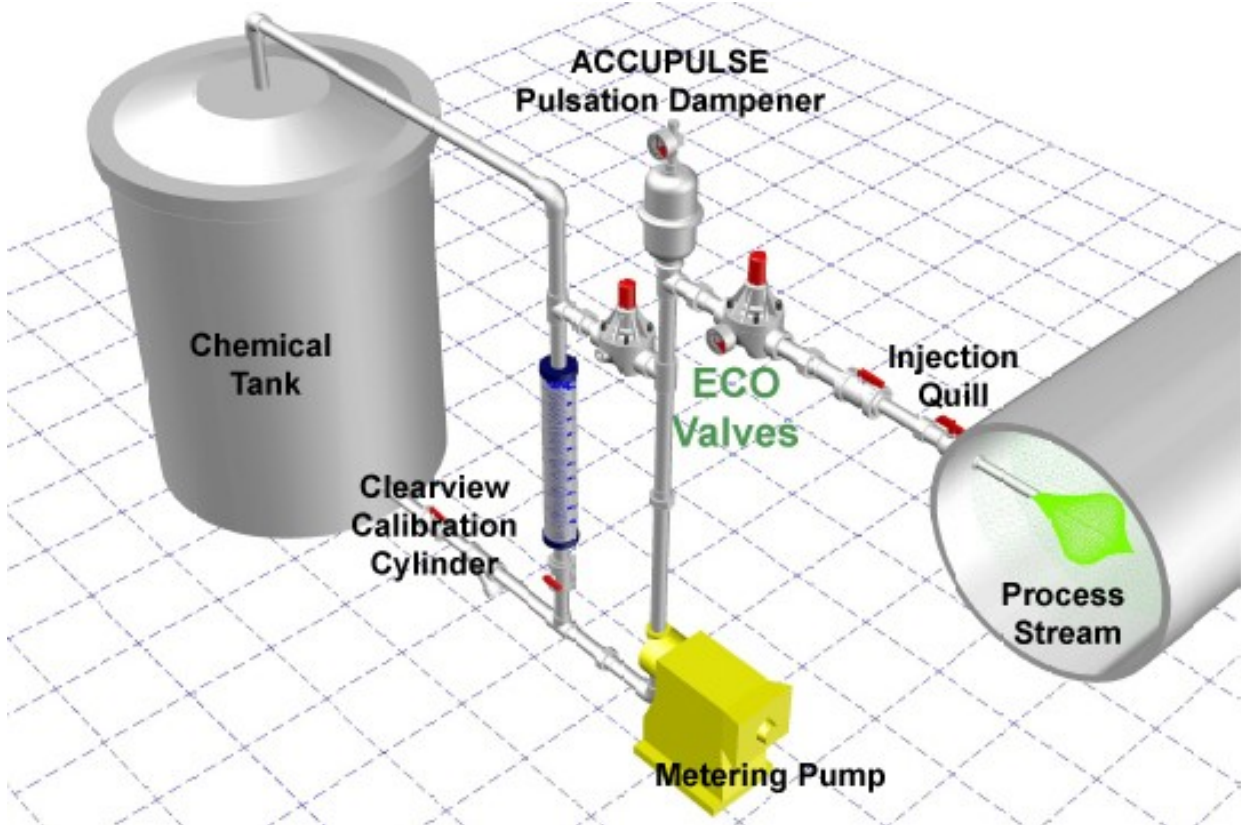

# Back Pressure/Pressure Relief Valve- High Temperature-Exploded Parts View

1/2" High Flow (ECO-55), 3/4" (ECO-75), 1" (ECO-100) ECO Valves

THIS DRAWING IS THE PROPERTY OF PRIMARY FLUID SYSTEMS INC. FROM WHICH A WRITTEN CONSENT FOR APPROVAL SHALL BE REQUIRED PRIOR TO COPYING.

## ECO VALVE® B-SERIES BACK PRESSURE VALVE (HIGH TEMPERATURE)

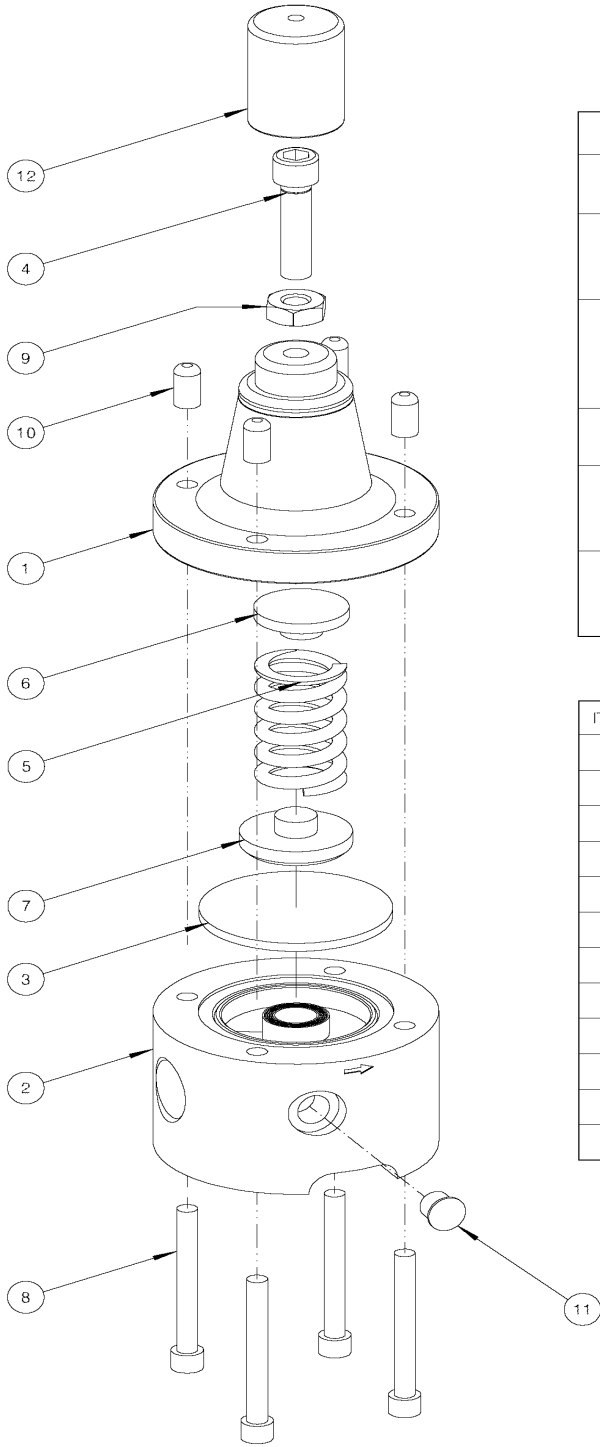

CHART OF MATERIAL/SIZE CODING: SERIES-B

μ = SS = (316L STAINLESS STEEL)  
μ = A = (ALUMINUM)\*

∞ = SS = (316L STAINLESS STEEL)  
∞ = HASTC = (HASTELLOY C STEEL)  
∞ = ALL20 = (ALLOY 20 STEEL)

Ω = NPT  
Ω = BSPT  
Ω = SOC  
Ω = FLG

φ = V = VITON\*  
φ = E = OPTIONAL EPDM

σ = 55 = 1/2" (DN 15) HIGH FLOW VALVES  
σ = 75 = 3/4" (DN 20) VALVES  
σ = 10 = 1" (DN 25) VALVES

Θ = Y = YELLOW = 1/2" (DN 15) HIGH FLOW VALVES  
Θ = R = RED = 3/4" (DN 20) VALVES  
Θ = B = BLUE = 1" (DN 25) VALVES

ITEM	QTY	NAME	DESCRIPTION
1	1	BONNET	EVT - 1μ - 51
2	1	BODY	EVB - 2∞ - σ - Ω
3	1	DIAPHRAGM	EVD - 3- 51 - φ
4	1	ADJUSTING BOLT	EVAB - 4 - 51
5	1	SPRING	EVS - 5 - 51
6	1	TOP DISC	EVTD - 6 - 5T
7	1	BOTTOM DISC	EVBD - 7 - 5T
8	4	BOLTS	EVSB - 8A - 51
9	1	LOCK NUT	EVBN - 9 - 51
10	4	BOLT CAP COVER	EVBC - 10 - 51
11	2	GAUGE PORT CAP	EVGC - 11
12	1	BONNET CAP COVER	EVTC - 12 - Θ - 51

SYMBOLS REQUIRE CODES FROM ABOVE CHART  
\* STANDARD CONSTRUCTION

<b>PRIMARY FLUID SYSTEMS INC.</b> 1050 COOKE BLVD, BURLINGTON, ONTARIO L7T 4A8	PROJECT: ECO	SHT: 1 OF 1	DRAWN BY: TJ
	DATE DRAWN: 8/15/2016	SCALE: NTS	UNITS: INCHES
TITLE: ECO BACK PRESSURE OR PRESSURE RELIEF HIGH TEMPERATURE VALVE EXPLODED PARTS VIEW	MATERIAL: SEE CHART	DWG NO.:	REV# 0
DWG NAME: ECO B-SERIES HIGH TEMPERATURE	APPROVED BY:	CHECKED BY:	OPTIONAL TOLERANCE 0.005 ±0.20"
DWG TYPE: PLANAR VIEW 2D	THIRD ANGLE PROJECTION		11 X 17 SHEET SIZE <b>B</b>

# Parts Ordering Information

## KEY

1

EVT-1\*\*-51

**Material:**  
 SS= 316L Stainless Steel  
 A= Aluminum\*

**Connection:**  
 A= NPT  
 B= BSPT  
 C= S/W N.A.  
 D= S/W Metric  
 E= Flg. ASME  
 F= Flg. DIN

2

EVB -2\*\*\* - \*\* - \*\*

**Size:**  
 55= 1/2" valve  
 75= 3/4" valve  
 100= 1" valve

3

EVD-3-51- \*\*

**Material:**  
 SS =316L Stainless Steel  
 HASTC= Hastelloy C Steel  
 ALL20= Alloy 20 Steel

4

EVAB-4-51

**Material:**  
 V =Viton\*  
 E =EPDM

5

EVS-5-51

6

EVTD-6-5T

7

EVBD-7-5T

8

EVSB-8A-51

8A

EVSB-8A-\*

**Size:**  
 55 = 1/2" S/S valve  
 75 = 3/4" S/S valve  
 100= 1" S/S valve

**Colour:**  
 Y= Yellow =1/2" valve  
 R= Red =3/4" valve  
 B= Blue =1" valve

9

EVBN-9-51

10

EVBC-10-51

11

EVGC-11

12

EVTC-12-\*\*-51

\*Standard Construction



## Flow Rates

Subject: Flow capacity through ECO VALVE, back pressure/pressure sustaining and pressure relief valves.

Under continuous flow conditions: @ **100 PSI** with ambient temperature water with the valve set @ 50PSIG.

½" valve	34	USGPM
¾" valve	36	USGPM
1" valve	38	USGPM

Note: Capacities will increase with pressure.(if pressure is doubled, flow rate will approximately double)

For capacities of valves with pulsating flow use approximately 1/3 of the above given flow values.

**TEMPERATURE EFFECTS:** Thermoplastics and thermosets will decrease in tensile strength as the temperature increases; therefore, the working pressure must be reduced accordingly. The following factors will apply:

### Temperature Correction Factors Thermoplastics

Operating Temperatures		{Factors}			
F	C	PVC	CPVC	PP	PVDF
70	21	1.00	1.00	1.00	1.00
80	27	1.00	1.00	1.00	1.00
90	32	1.00	1.00	1.00	1.00
100	38	.90	1.00	1.00	1.00
110	43	.83	1.00	.91	1.00
115	46	.75	1.00	.87	1.00
120	49	.66	1.00	.83	1.00
125	52	.58	.97	.79	1.00
130	54	.50	.95	.75	1.00
140	60	.33	.90	.66	1.00
150	66	NR	.80	.60	.97
160	71	NR	.70	.53	.93
170	77	NR	.60	.43	.86
180	82	NR	.50	.33	.80
200	93	NR	.33	NR	.66
210	99	NR	NR	NR	.60
240	116	NR	NR	NR	.40
280	138	NR	NR	NR	.16

**Example:**

Maximum Pressure for PVDF valve at 280°F (138°C)

Factor = 0.16 x 150psig = 24psig max. pressure

Factor = 0.16 x 1034kPa = 165.44kPa max. pressure

The maximum pressure rating for valves regardless of size is 150 PSIG (1034 kPa) at 73° F (22°C)

**NR** = not recommended

Primary Fluid Systems, Inc. takes no responsibility for the enclosed data.

# Back Pressure Valves ( Pressure Retaining Valves)

## 1/2" High Flow, 3/4", 1" ECO Valves

Body Configuration Model ECO-55

Dimensions

ECO-75

ECO-100

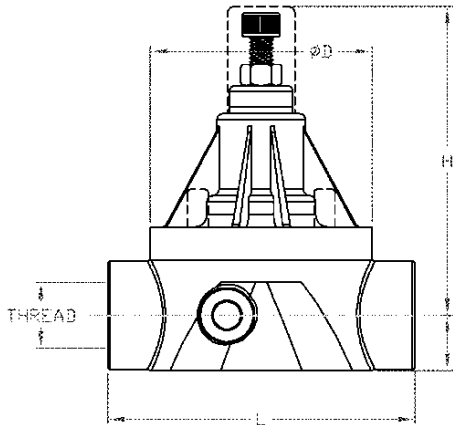

Threaded Female

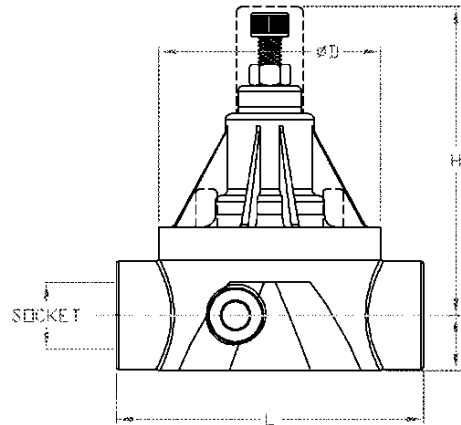

Socket

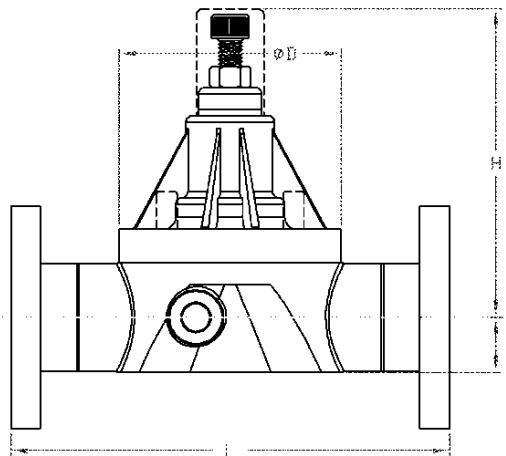

Flanged

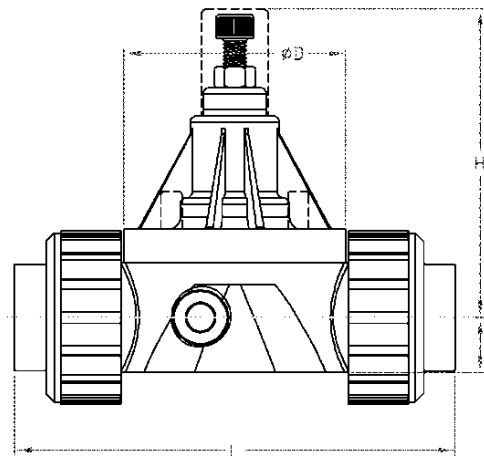

Union

Nominal Size		PVC, CPVC, PP & PVDF						
NPS Inch	DIN DN	Ø D inch mm	h inch mm	H inch mm	L inch mm	L inch mm	L inch mm	L inch mm
SERIES-B					Thrd	Soc	Flg	Union
1/2 High Flow	15	3.50 88.9	0.88 22.4	4.80 121.9	4.85 123.2	4.85 123.2	6.93 176.0	7.30 185.4
3/4	20	3.50 88.9	0.88 22.4	4.80 121.9	4.85 123.2	4.85 123.2	7.17 182.1	7.30 185.4
1	25	3.50 88.9	0.88 22.4	4.80 121.9	4.85 123.2	4.85 123.2	7.48 190.0	7.30 185.4

Nominal Size		316L SS						
NPS Inch	DIN DN	Ø D inch mm	h inch mm	H inch mm	L inch mm	L inch mm	L inch mm	L inch mm
SERIES-B					Thrd	Soc	Flg	
1/2 High Flow	15	3.50 88.9	0.63 16.0	4.80 121.9	3.50 88.9	3.50 88.9	7.17 182.1	7.17 182.1
3/4	20	3.50 88.9	0.73 18.5	4.80 121.9	3.50 88.9	3.50 88.9	7.50 190.5	7.50 190.5
1	25	3.50 88.9	0.86 21.8	5.10 129.5	3.50 88.9	3.50 88.9	7.66 194.6	7.66 194.6

## **LIMITED WARRANTY**

Primary Fluid Systems Inc. (Primary) warrants its products against defects in workmanship or materials for one (1) year under normal use. Three-(3) year available when application card is completed and returned to factory.

Primary's obligations and liabilities under this warranty shall be limited to replacement of the product, or a refund of an amount not to exceed the purchase price of the product(s) to which such warranty claim is made. Repairs or replacements are made subject to our inspection of the returned product(s). Primary's decision of one of these alternatives shall be the buyer's exclusive remedy.

This warranty does not extend to damage by corrosion or other decomposition by chemical action. Primary does not warrant damages caused by (a) improper use of the product, (b) unauthorized modification or attachment to product, (c) misuse, abuse, accident or negligent handling or installation of product, or (d) alterations or repairs made by purchaser.

The materials of construction offered are recommendations only, subject in all cases to acceptance by purchaser. These recommendations do not constitute any guarantee against corrosion or decomposition, but are based on previous experience and best available information of the industry.

Statements and instructions set forth herein are based on the best information and practices known to Primary, but it should not be assumed that every acceptable safety procedure is contained herein. Of necessity Primary cannot guarantee that actions in accordance with such statements and instructions will result in the complete elimination of hazards and it assumes no liability for accidents that may occur.

Except as specifically provided herein, Primary makes no warranty, representations, promise or guarantee, either express or implied, statutory or otherwise, with respect to the product and technical information provided, including the products' quality, performance, merchantability, or fitness for a particular purpose.

In no event will Primary be liable for indirect, special, incidental, economic, covert or consequential damages arising out of the use or inability to use the product, including without limitation, damages or costs relating to the loss of profits, business and good will even if advised of the possibility of such damages. In no event shall Primary's liability exceed the amount paid by you for the product.

The warranty and remedies set forth herein are exclusive and in lieu of all others, oral or written, express or implied. No Primary dealer, distributor, agent or employee is authorized to make any modification or addition to this warranty. This warranty gives you specific legal rights and you may also have other rights which vary from state to state.

## Notes