

THIS DRAWING IS THE PROPERTY OF PRIMARY FLUID SYSTEMS INC. FROM WHICH A WRITTEN CONSENT FOR APPROVAL SHALL BE REQUIRED PRIOR TO COPYING.

	NO.	NAME	DESCRIPTION
	1	MAX ALLOWABLE OPERATING TEMPERATURE	140°F (60°C)
	2	MAX ALLOWABLE OPERATING PRESSURE	15 PSIG
CONNECTIONS	3	BOTTOM PORT CONNECTION	1"
	4	TOP PORT CONNECTION	N/A
	5	TYPE	NPT
MATERIALS	6	CYLINDER	CLEAR PVC
	7	END CAP	PVC
	8	GLUE	CPVC, CHEMICAL RESISTANT
INPUT DATA	9	VOLUME SIZE	2000 ML / 32 GPH
SCALE	10	BI DIRECTIONAL GRADUATIONS	20 ML / .25 GPH DIVISIONS
	11	ALL CYLINDERS ARE RATED FOR LIQUID SERVICE ONLY	√
COMMENTS	12	CYLINDERS ARE NOT PRESSURE VESSELS	√
		NSF 61 APPROVED	

CLEARVIEW®
CV#1 PVC CALIBRATION CYLINDER

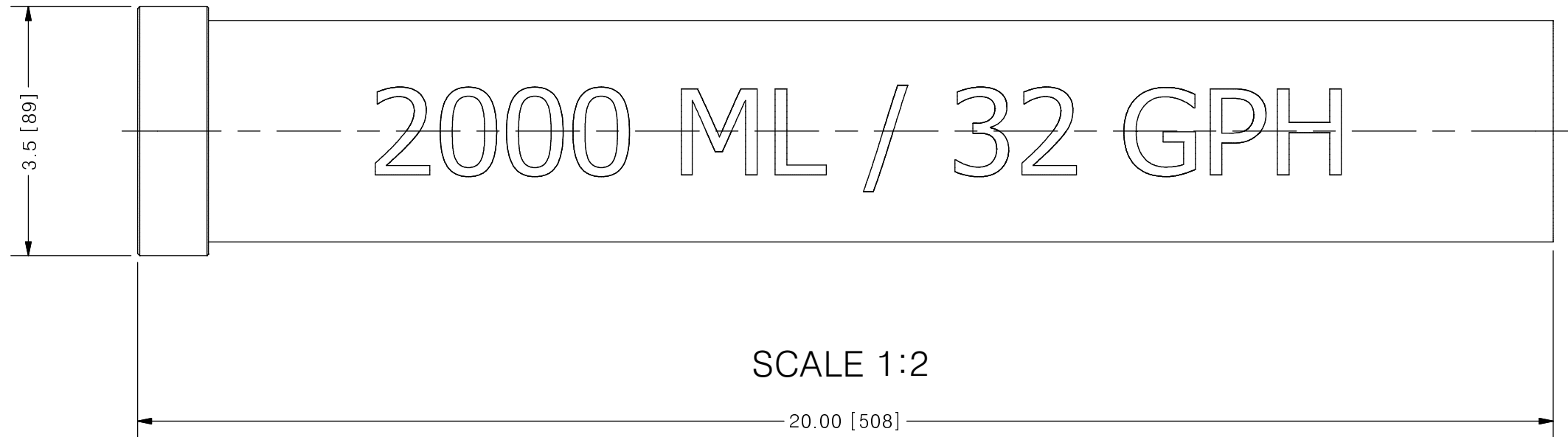
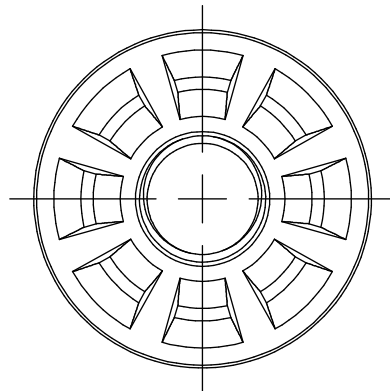

REV	DESCRIPTION	DATE	NAME
0	NEW DRAWING	--	--

REVISION HISTORY

PRIMARY FLUID SYSTEMS INC. 1050 COOKE BLVD, BURLINGTON, ONTARIO L7T 4A8		PROJECT: CV	SHT: 1 OF 1	DRAWN BY: NG
TITLE: 2000 ML CALIBRATION CYLINDER WITH 1" NPT CONNECTION		DATE DRAWN: 5/9/2016	SCALE: 1:2	UNITS: INCH [mm]
DWG NAME: CV CYLINDER DWG TYPE: PLANAR VIEW		MATERIAL: SEE CHART	DWG NO: CV#1-2000_R0	REV# 0
APPROVED BY: _____ CHECKED BY: _____		DIMENSIONAL TOLERANCE 0.X = ± 0.25" 0.XX = ± 0.25" 0.XXX = ± 0.25"		SHEET SIZE: B

