

THIS DRAWING IS THE PROPERTY OF PRIMARY FLUID SYSTEMS INC. FROM WHICH A WRITTEN CONSENT FOR APPROVAL SHALL BE REQUIRED PRIOR TO COPYING.

	NO.	NAME	DESCRIPTION
	1	MAX ALLOWABLE OPERATING TEMPERATURE	140°F (60°C)
	2	MAX ALLOWABLE OPERATING PRESSURE	15 PSIG
	3	LEAK TEST	YES
CONNECTIONS	4	BOTTOM PORT CONNECTION	2"
	5	TOP PORT CONNECTION	2"
	6	TYPE	NPT
MATERIALS	7	CYLINDER	BOROSILICATE GLASS
	8	END CAPS	CPVC CORZAN OR PVDF
	9	GLASS SEALING 'O' RINGS	VITON (STD), EPDM (OPTION)
MATERIAL NON WETTED	10	OUTER SHIELD	POLYCARBONATE
	11	UNION NUTS	PVC
	12	SHIELD SEALING 'O' RINGS	BUNA-N
INPUT DATA	13	VOLUME SIZE	6000 ML
SCALE	14	GRADUATION	50 ML
COMMENTS	15	ALL CYLINDERS ARE RATED FOR LIQUID SERVICE ONLY	
	16	CYLINDERS ARE NOT PRESSURE VESSELS	

CLEARVIEW® CVG GLASS CALIBRATION CYLINDER

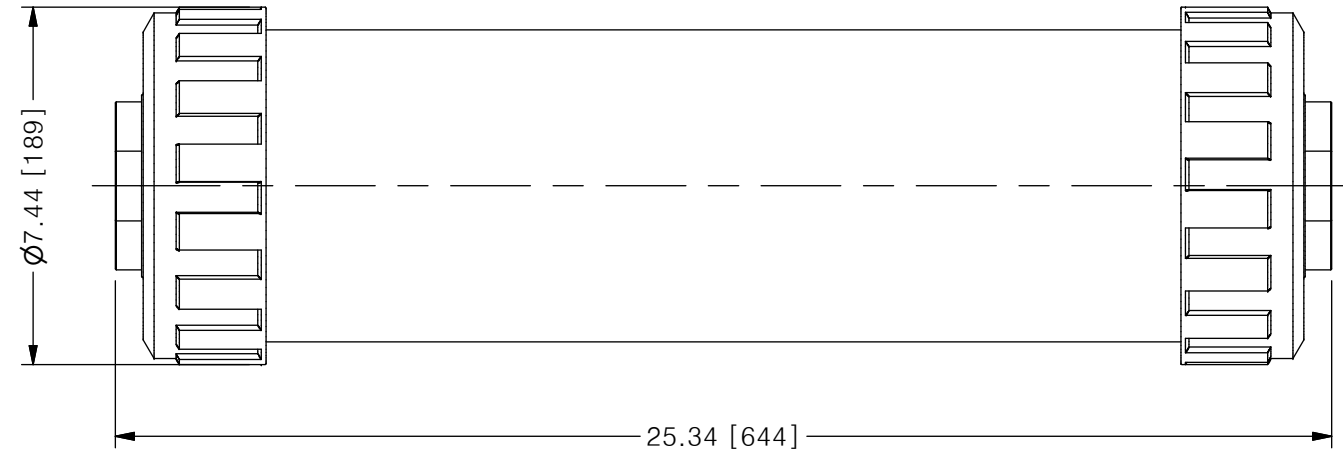
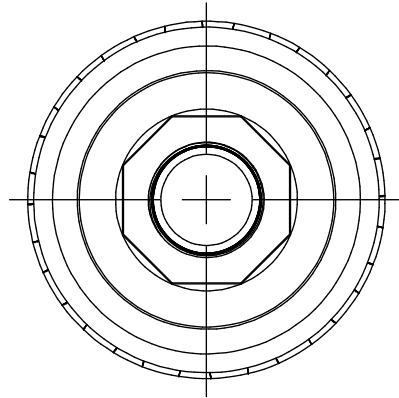
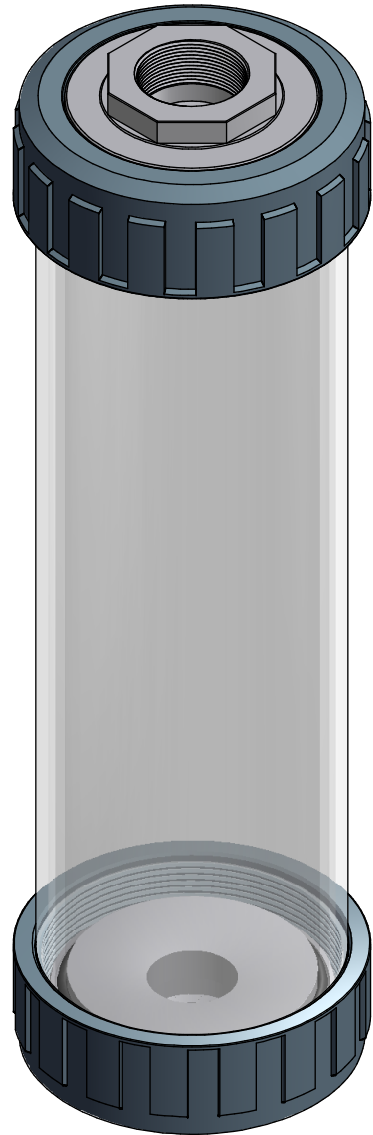

SCALE 1 : 4

REV	DESCRIPTION	DATE	NAME
0	NEW DRAWING	--	--

REVISION HISTORY

PRIMARY FLUID SYSTEMS INC. 1050 COOKE BLVD, BURLINGTON, ONTARIO L7T 4A8		PROJECT: CVG	SHT: 1 OF 1	DRAWN BY: FS
TITLE: 6000 ML CALIBRATION CYLINDER WITH 2" NPT PORTS		DATE DRAWN: 11/5/2021	SCALE: 1 : 4	UNITS: INCH[mm]
DWG NAME: ASSEMBLY DWG TYPE: PLANAR VIEW		MATERIAL: SEE CHART	DWG NO: CVG-6000-PV-20N_R0	DIMENSIONAL TOLERANCE 0.X = ± 0.25" 0.XX = ± 0.25" 0.XXX = ± 0.25"
APPROVED BY: _____ CHECKED BY: _____		THIRD ANGLE PROJECTION		REV# 0 SHEET SIZE: B