

THIS DRAWING IS THE PROPERTY OF PRIMARY FLUID SYSTEMS INC. FROM WHICH A WRITTEN CONSENT FOR APPROVAL SHALL BE REQUIRED PRIOR TO COPYING.

	NO.	NAME	DESCRIPTION
	1	MAX ALLOWABLE OPERATING TEMPERATURE	140°F (60°C)
	2	MAX ALLOWABLE OPERATING PRESSURE	15 PSIG
	3	LEAK TEST	YES
CONNECTIONS	4	BOTTOM PORT CONNECTION	1/2"
	5	TOP PORT CONNECTION	1/2"
	6	TYPE	NPT
MATERIALS	7	CYLINDER	BOROSILICATE GLASS
	8	END CAPS	PVC/CPVC
	9	GLASS SEALING 'O' RINGS	VITON
MATERIAL NON WETTED	10	OUTER SHIELD	POLYCARBONATE
	11	UNION NUTS	PVC
	12	SHIELD SEALING 'O' RINGS	BUNA-N
INPUT DATA	13	VOLUME SIZE	100 ML
SCALE	14	GRADUATION	1 ML
COMMENTS	15	ALL CYLINDERS ARE RATED FOR LIQUID SERVICE ONLY	
	16	CYLINDERS ARE NOT PRESSURE VESSELS	

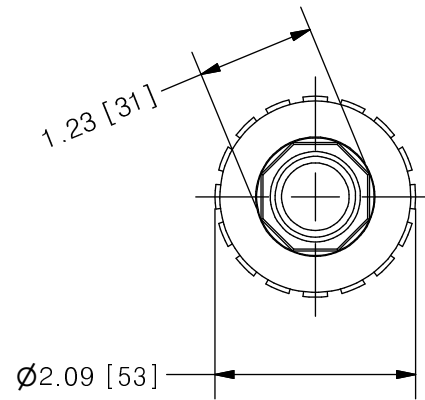

CLEARVIEW® CVG GLASS CALIBRATION CYLINDER

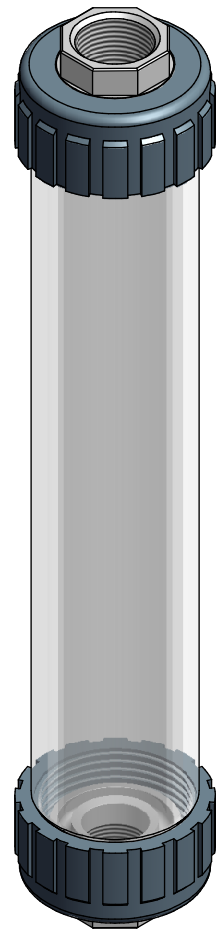
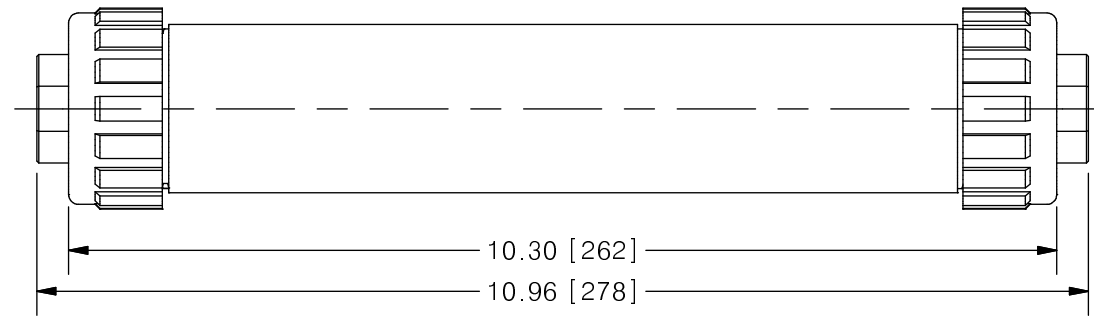

SCALE 1 : 2

REV	DESCRIPTION	DATE	NAME
5	REMODELLED FROM CVG-P--STD-4100-CAT REV 5	--	--

PRIMARY FLUID SYSTEMS INC. 1050 COOKE BLVD, BURLINGTON, ONTARIO L7T 4A8		PROJECT: CVG	SHT: 1 OF 1	DRAWN BY: NG
TITLE: 100 ML CALIBRATION CYLINDER WITH 1/2" NPT CONNECTION		DATE DRAWN: 6/23/2016	SCALE: 1:2	UNITS: INCH[mm]
DWG NAME: CVG CYLINDER DWG TYPE: PLANAR VIEW		MATERIAL: SEE CHART	DWG NO: CVG-100-PV-50N_R5	REV# 5
APPROVED BY: _____ CHECKED BY: _____		DIMENSIONAL TOLERANCE 0.X = ± 0.25" 0.XX = ± 0.25" 0.XXX = ± 0.25"		SHEET SIZE: B